



(19) **United States**

(12) **Patent Application Publication** (10) **Pub. No.: US 2005/0110403 A1**

Han et al.

(43) **Pub. Date: May 26, 2005**

(54) **FLAT PANEL DISPLAY FOR DISPLAYING SCREENS AT BOTH SIDES**

(57) **ABSTRACT**

(76) Inventors: **Dong-Won Han**, Suwon-si (KR);
Byung-Hee Kim, Suwon-si (KR)

A flat panel display comprises: a transparent substrate having a first display portion and a second display portion; at least one first organic light emitting diode positioned in the first display portion for emitting light in a first direction perpendicular to the transparent substrate, and having a first lower electrode, a first upper electrode, and a first organic emission layer interposed between the first lower electrode and the first upper electrode; and at least one second organic light emitting diode positioned in the second display portion for emitting light in a second direction opposite to the first direction, and having a second lower electrode, a second upper electrode, and a second organic emission layer interposed between the second lower electrode and the second upper electrode. As a result, the flat panel display is fabricated using one substrate to display both screens such that one of the screens is displayed while the other is not displayed. Accordingly, the thickness of electronic equipment employing the flat panel display may be reduced, and the power consumption of the electronic equipment may also be reduced.

Correspondence Address:

Robert E. Bushnell
Suite 300
1522 K Street, N.W.
Washington, DC 20005-1202 (US)

(21) Appl. No.: **10/980,338**

(22) Filed: **Nov. 4, 2004**

(30) **Foreign Application Priority Data**

Nov. 12, 2003 (KR) 2003-79945

Publication Classification

(51) **Int. Cl.⁷** **H01J 1/62; H01J 63/04**

(52) **U.S. Cl.** **313/512**

100

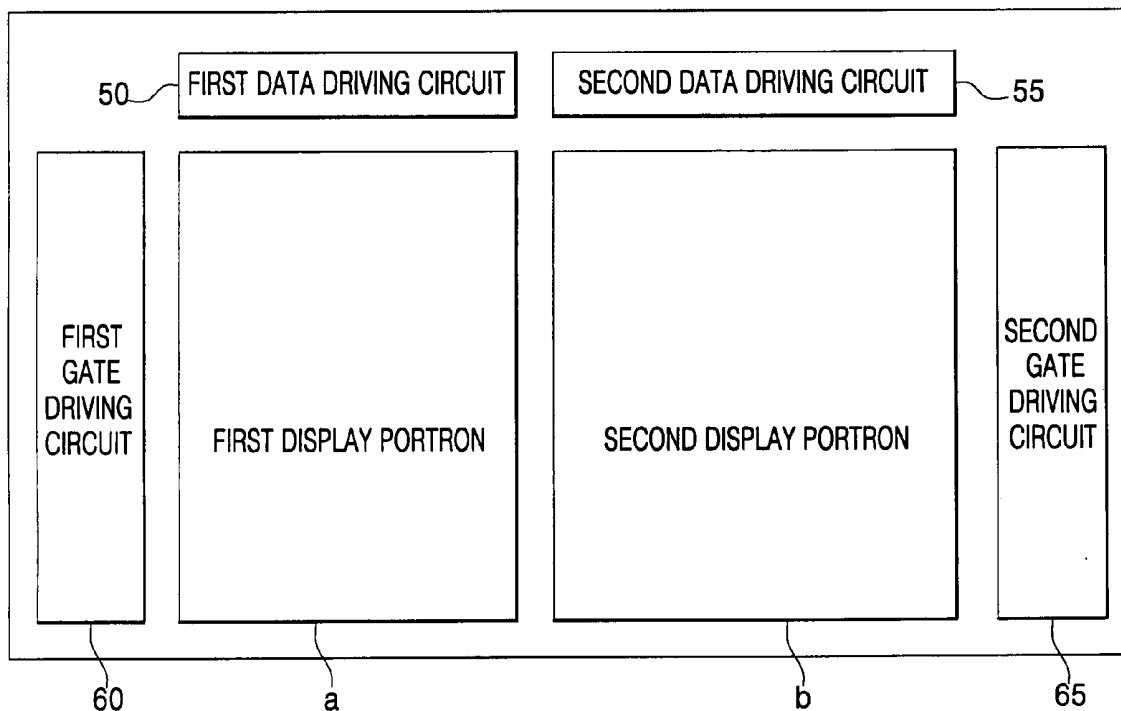

FIG. 1

100

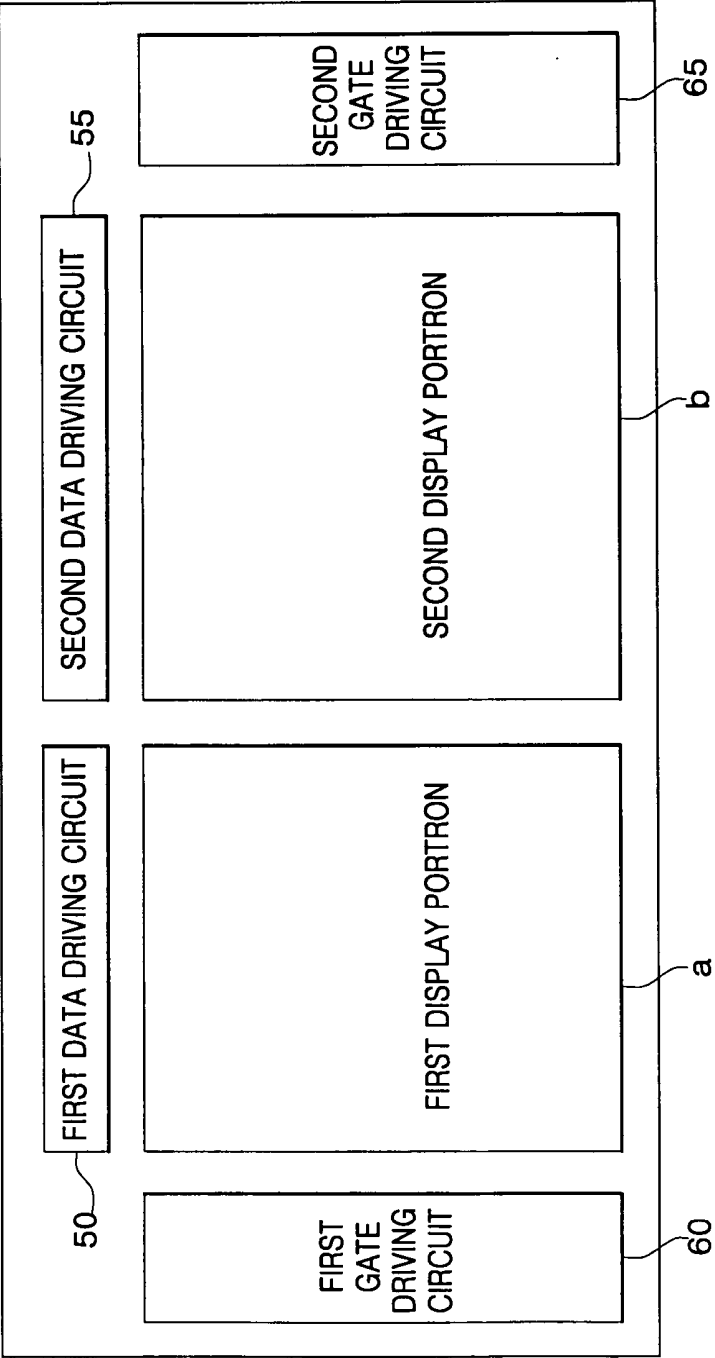

FIG. 2

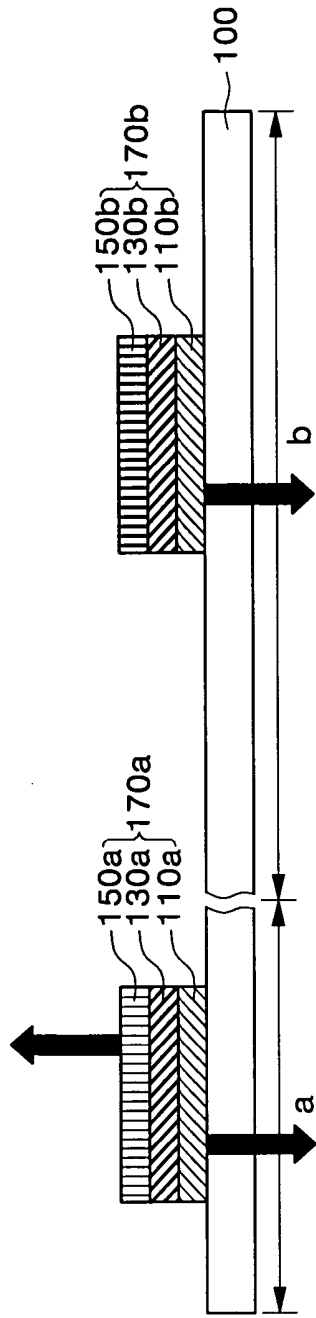

FIG. 3

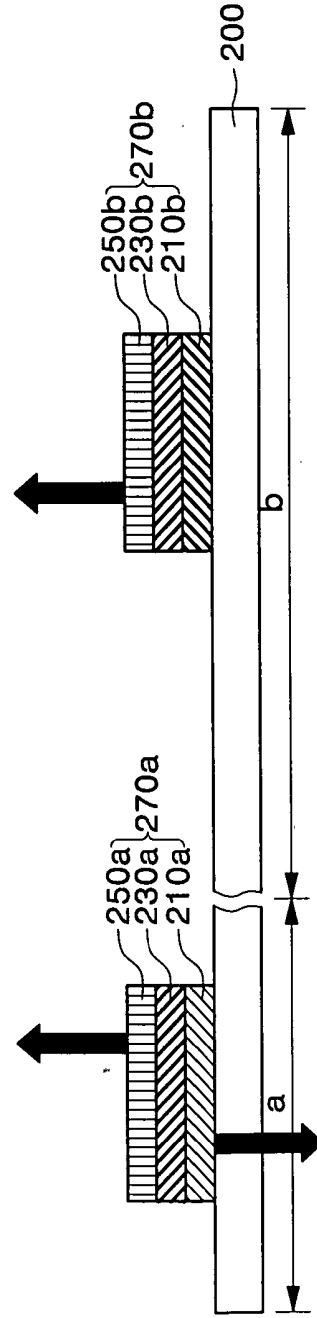

FIG. 4

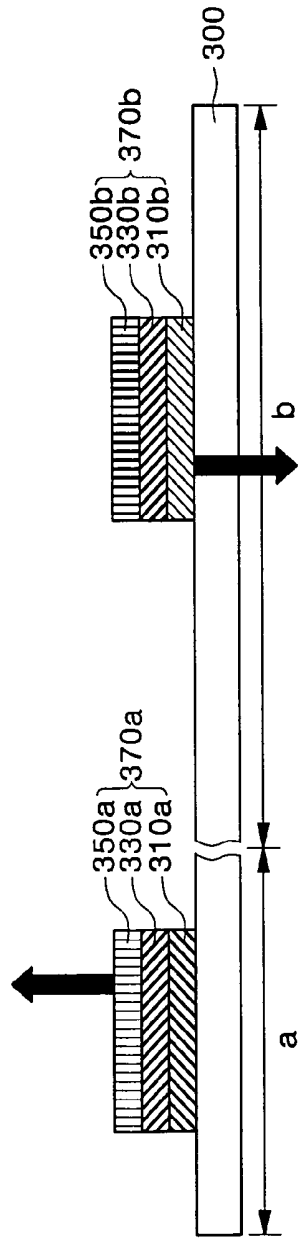

FIG. 5

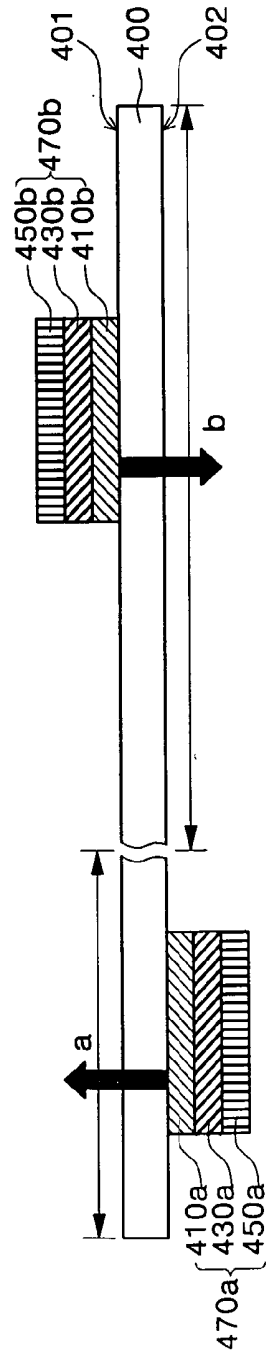

FIG. 7

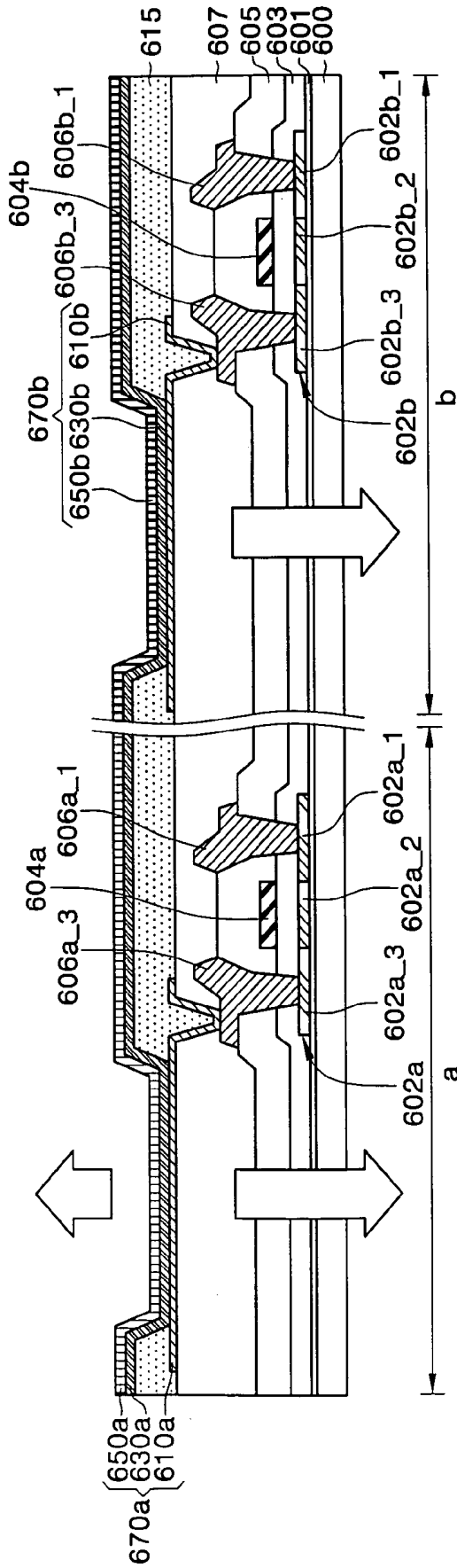

FIG. 8

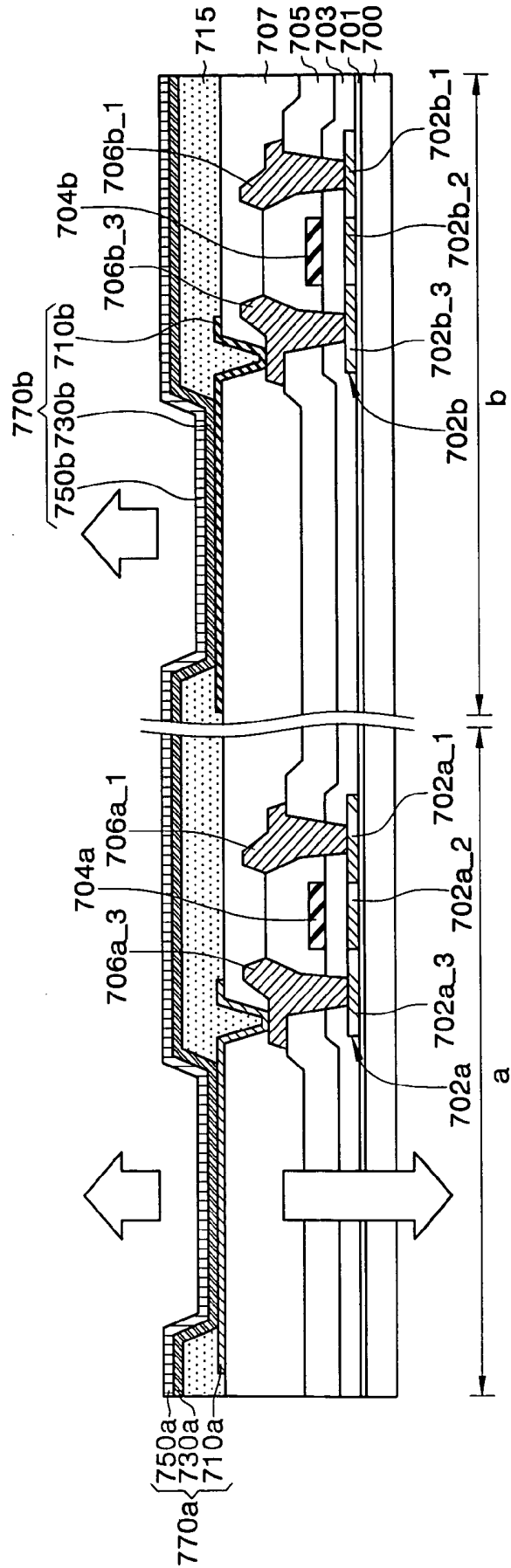

FIG. 9

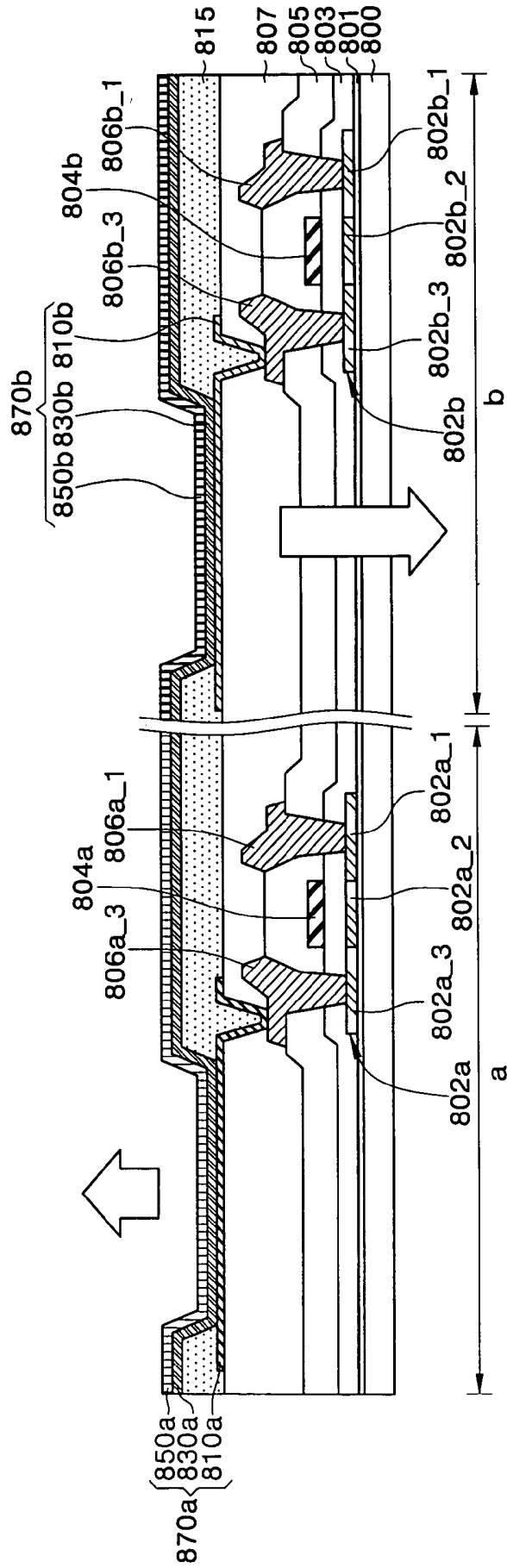

FIG. 10

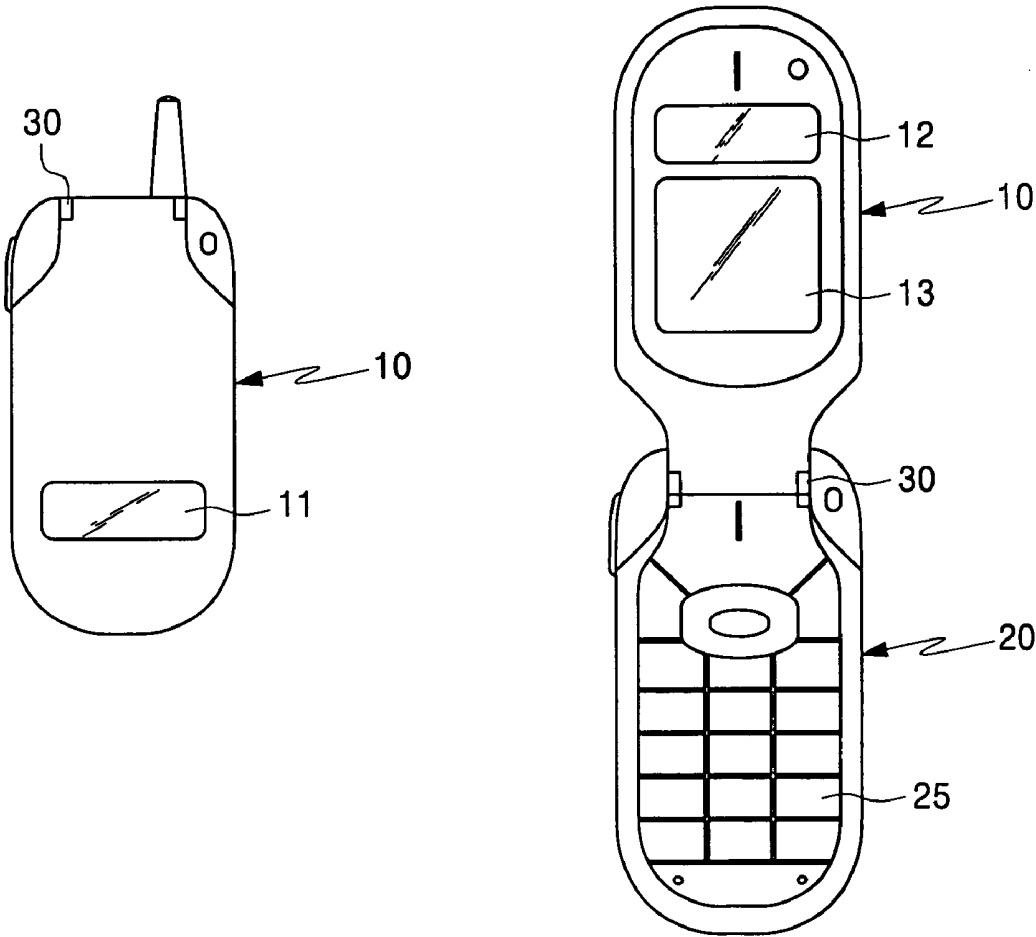
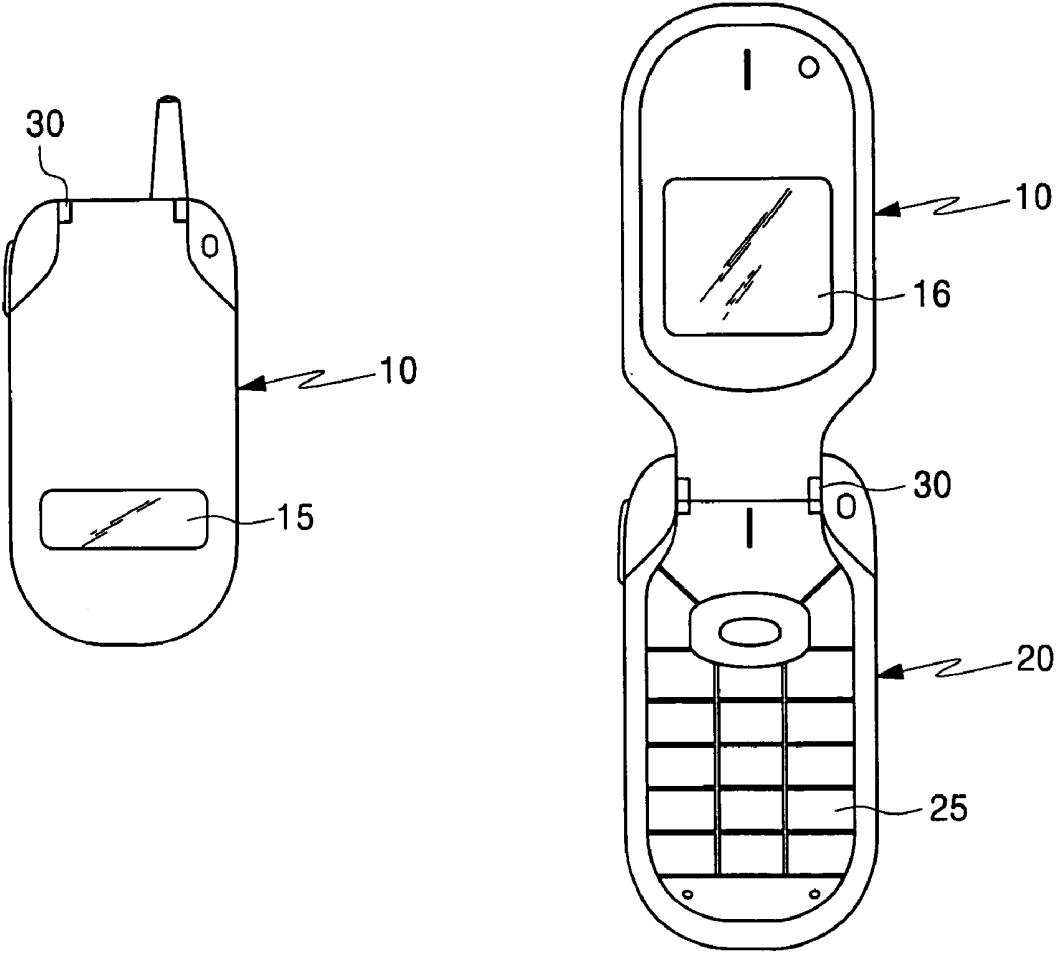

FIG. 11



FLAT PANEL DISPLAY FOR DISPLAYING SCREENS AT BOTH SIDES

CLAIM OF PRIORITY

[0001] This application makes reference to, incorporates the same herein, and claims all benefits accruing under 35 U.S.C. §119 from an application for FLAT PANEL DISPLAY FOR DISPLAYING SCREENS AT BOTH SIDES earlier filed in the Korean Intellectual Property Office on 12 Nov. 2003 and there duly assigned Ser. No. 2003-79945.

BACKGROUND OF THE INVENTION

[0002] 1. Technical Field

[0003] The present invention relates to a flat panel display and, more particularly, to a flat panel display capable of displaying screens at both sides.

[0004] 2. Related Art

[0005] Examples of electronic equipment employing a flat panel display include a mobile phone, a camcorder, a notebook computer, and so forth. One popular example of them is a folder type mobile phone, which has external and internal screens on external and internal surfaces of its cover, respectively, so that detailed information may be checked through the internal screen in its unfolded state and simple information may also be checked through the external screen in its folded state.

[0006] The representative flat panel display used for the mobile phone includes a liquid crystal display and an organic electroluminescence display, and a liquid crystal display panel should be separately inserted into the external and internal screens in order to fabricate the mobile phone with external and internal screens using the liquid crystal display. This causes the thickness of the mobile phone to be increased.

[0007] To deal with the above-mentioned problem, there have been attempts to fabricate the mobile phone having internal and external screens by means of a transparent organic light-emitting display. The transparent organic light-emitting display is an emissive display that does not require a backlight, and may advantageously display both screens with only one panel so as to reduce the thickness of the mobile phone having internal and external screens. However, the transparent organic light-emitting display presents screen displays on both sides at the same time, so that it displays the internal screen in addition to the external screen even when only the external screen of the mobile phone is used, which causes power consumption to be significantly increased.

SUMMARY OF THE INVENTION

[0008] The present invention solves the aforementioned problems associated with conventional devices by providing a flat panel display for displaying internal and external screens while reducing power consumption as well as the thickness of the electronic equipment.

[0009] In an exemplary embodiment of the present invention, the flat panel display for displaying screens on both sides includes: a transparent substrate having a first display portion and a second display portion; at least one first organic light emitting diode positioned in the first display

portion for emitting light in at least a first direction perpendicular to the transparent substrate, and having a first lower electrode, a first upper electrode, and a first organic emission layer interposed between the first lower electrode and the first upper electrode; and at least one second organic light emitting diode positioned in the second display portion for emitting light in a second direction opposite to the first direction, and having a second lower electrode, a second upper electrode, and a second organic emission layer interposed between the second lower electrode and the second upper electrode.

[0010] The first and second organic light emitting diodes may be positioned on the same surface of the transparent substrate. In this case, in the first organic light emitting diode, the first lower electrode may be a reflective electrode and the first upper electrode may be a transparent electrode. In the second organic light emitting diode, the second lower electrode may be a transparent electrode and the second upper electrode may be a reflective electrode. In the meantime, both the first lower electrode and the first upper electrode may be a transparent electrode in the first organic light emitting diode, and the second lower electrode may be a transparent electrode and the second upper electrode may be a reflective electrode in the second organic light emitting diode. Alternatively, both the first lower electrode and the first upper electrode may be a transparent electrode in the first organic light emitting diode, and the second lower electrode may be a reflective electrode and the second upper electrode may be a transparent electrode in the second organic light emitting diode.

[0011] Conversely, the first organic light emitting diode may be positioned on a surface opposite to a surface on which the second organic light emitting diode is positioned. In this case, in the first organic light emitting diode, the first lower electrode may be a transparent electrode and the first upper electrode may be a reflective electrode. In the second organic light emitting diode, the second lower electrode may be a transparent electrode and the second upper electrode may be a reflective electrode. Alternatively, the first lower electrode may be a reflective electrode and the first upper electrode may be a transparent electrode in the first organic light emitting diode, and the second lower electrode may be a reflective electrode and the second upper electrode may be a transparent electrode in the second organic light emitting diode.

[0012] The flat panel display may be used for a folder type mobile phone.

BRIEF DESCRIPTION OF THE DRAWINGS

[0013] A more complete appreciation of the invention, and many of the attendant advantages thereof, will be readily apparent as the same becomes better understood by reference to the following detailed description when considered in conjunction with the accompanying drawings in which like reference symbols indicate the same or similar components, wherein:

[0014] FIG. 1 is a plan view illustrating a flat panel display in accordance with any one of the first to eighth embodiments of the present invention;

[0015] FIGS. 2 to 6 are cross-sectional views illustrating a method for fabricating a flat panel display in accordance with the first to fifth embodiments of the present invention, respectively;

[0016] FIGS. 7 to 9 are cross-sectional views illustrating a method for fabricating a flat panel display in accordance with the sixth to eighth embodiments of the present invention, respectively;

[0017] FIG. 10 is a plan view illustrating a folder type mobile phone in the folded and unfolded states and employing the flat panel display in accordance with any one of the first, second, sixth, and seventh embodiments of the present invention; and

[0018] FIG. 11 is a plan view illustrating a folder type mobile phone in the folded and unfolded states and employing the flat panel display in accordance with any one of the third to fifth, and eighth embodiments of the present invention.

DETAILED DESCRIPTION OF THE INVENTION

[0019] The present invention will now be described more fully hereinafter with reference to the accompanying drawings, in which preferred embodiments of the invention are shown. This invention may, however, be embodied in different forms and should not be construed as limited to the embodiments set forth herein.

[0020] FIG. 1 is a plan view illustrating a flat panel display in accordance with any one of the first to eighth embodiments of the present invention.

[0021] Referring to FIG. 1, a substrate 100 has a first display portion (a) and a second display portion (b). The second display portion (b) is spaced apart from the first display portion (a). Each of the first display portion (a) and the second display portion (b) has at least one unit pixel (not shown). The unit pixel (not shown) has an organic light emitting diode (OLED), and the OLED positioned in the first display portion (a) is referred to as a first OLED, and the OLED positioned in the second display portion (b) is referred to as a second OLED.

[0022] The first OLED and the second OLED may be positioned on the same surface, for example, on a top surface of the substrate 100. Alternatively, one of the first OLED and the second OLED may be positioned on the top surface of the substrate 100 and the other may be positioned on a bottom surface of the substrate 100.

[0023] The first display portion (a) emits light in a direction different from that of the second display portion (b). Accordingly, when both the first display portion (a) and the second display portion (b) are positioned on the top surface of the substrate 100, the first OLED positioned in the first display portion (a) may be a transparent type for emitting light in a direction perpendicular to the substrate 100, namely, in a direction toward the substrate and in a direction away from the substrate, and the second OLED positioned in the second display portion (b) may be a bottom-emission type for emitting light in a direction toward the substrate (first and seventh embodiments). Alternatively, the first OLED may be a transparent type for emitting light in a direction toward the substrate and in a direction away from the substrate, and the second OLED may be a top-emission type for emitting light in a direction away from the substrate (second and eighth embodiments). Alternatively, the first OLED may be a top-emission type for emitting light in a direction away from the substrate and the second OLED

may be a bottom-emission type for emitting light in a direction toward the substrate (third and ninth embodiments). Accordingly, a flat panel display capable of displaying screens at both sides, namely, in a direction toward the substrate and in a direction away from the substrate, may be obtained.

[0024] Alternatively, when one of the first display portion (a) and the second display portion (b) is positioned on the top surface of the substrate 100 and the other is positioned on the bottom surface of the substrate 100, both the first OLED and the second OLED positioned on the first display portion (a) and the second display portion (b), respectively, may be bottom-emission types for emitting light in a direction toward the substrate (fourth embodiment). Meanwhile, both the first OLED and the second OLED positioned on the first display portion (a) and the second display portion (b), respectively, may be top-emission types for emitting light in a direction away from the substrate (fifth embodiment). Accordingly, a flat panel display capable of displaying both screens in directions opposite to each other may be obtained. In addition, at least one of the first display portion (a) and the second display portion (b) is a top-emission type or a bottom-emission type for displaying a screen in only one direction, and therefore the top-emission type or the bottom-emission type does not need to be driven when the screen is displayed in a direction opposite to the one direction, which leads to a reduction in power consumption. As a result, a flat panel display for displaying screens at both sides may be implemented while power consumption may also be reduced.

[0025] The first OLED positioned in the first display portion (a) and the second OLED positioned in the second display portion (b) may be driven by an external driving circuit externally mounted by means of Tape Carrier Package (TCP), Chip on Glass (COG), or Chip on Film (COF). Conversely, as shown in FIG. 1, the first OLED may be driven by a first data driving circuit 50 and a first gate driving circuit 60 positioned in a peripheral region of the first display portion (a), and the second OLED may be driven by a second data driving circuit 55 and a second gate driving circuit 65 positioned in a peripheral region of the second display portion (b).

[0026] FIG. 2 is a cross-sectional view illustrating a method for fabricating a flat panel display in accordance with the first embodiment of the present invention. The flat panel display in accordance with the first embodiment is fabricated to include both a transparent OLED (TOLED) and a bottom-emission OLED on one substrate.

[0027] Referring to FIG. 2, a transparent substrate 100 having a first display portion (a) and a second display portion (b) is provided. The transparent substrate 100 may be a glass substrate or a plastic substrate. At least one first lower electrode 110a and at least one second lower electrode 110b are formed on the first display portion (a) and the second display portion (b), respectively. The lower electrodes 110a and 110b are transparent electrodes, and, for example, Indium Tin Oxide (ITO) or Indium Zinc Oxide (IZO) is used for the lower electrodes when they are anodes. A first organic emission layer 130a and a second organic emission layer 130b are formed on the first and second lower electrodes 110a and 110b, respectively. A first upper electrode 150a and a second upper electrode 150b are formed on

the first and second organic emission layers **130a** and **130b**, respectively. The first upper electrode **150a** is a transparent electrode, and a thin metal layer having a low work function, for example, Mg, Ca, Al, Ag, Ba, or an alloy thereof, is used to form the first upper electrode having a thickness of 100 Å or less when it is a cathode. Forming the first upper electrode **150a** may further include forming an ITO layer on the thin metal layer. The second upper electrode **150b** is a reflective electrode, and a metal layer having a low work function, for example, Mg, Ca, Al, Ag, Ba, or an alloy thereof, is used to form the second upper electrode having a thickness of 500 Å or more when it is a cathode. The first upper electrode **150a** as the transparent electrode and the second upper electrode **150b** as the reflective electrode may each be formed using a shadow mask or the like.

[0028] As a result, at least one first OLED **170a** and at least one second OLED **170b** are formed in the first display portion (a) and the second display portion (b), respectively. The first OLED **170a** is a transparent type in which the first lower electrode **110a** and the first upper electrode **150a** are transparent electrodes to emit light in a direction toward the substrate and in a direction away from the substrate, and the second OLED **170b** is a bottom-emission type in which the second lower electrode **110b** is a transparent electrode and the second upper electrode **150b** is a reflective electrode to emit light only in a direction toward the substrate. Accordingly, the substrate **100** may be used to display both screens, namely, in a direction toward the substrate and in a direction away from the substrate, and the second OLED **170b** is not driven when the screen is displayed in a direction away from the substrate, thereby reducing its power consumption.

[0029] Furthermore, the OLEDs **170a** and **170b** may be passive matrix types or active matrix types. When the OLEDs **170a** and **170b** are the active matrix types, the substrate **100** has thin film transistors to be electrically connected to the lower electrodes **110a** and **110b**, respectively.

[0030] FIG. 3 is a cross-sectional view illustrating a method for fabricating a flat panel display in accordance with the second embodiment of the present invention. The flat panel display in accordance with the second embodiment is fabricated to include both a transparent OLED and a top-emission OLED on one substrate.

[0031] Referring to FIG. 3, a transparent substrate **200** having a first display portion (a) and a second display portion (b) is provided. The transparent substrate **200** may be a glass substrate or a plastic substrate. At least one first lower electrode **210a** and at least one second lower electrode **210b** are formed on the first display portion (a) and the second display portion (b), respectively. The first lower electrode **210a** is a transparent electrode, and, for example, ITO or IZO is used for the first lower electrode when it is an anode. The second lower electrode **210b** is a reflective electrode, and, for example, Ag, Al, Ni, Pt, Pd, or an alloy thereof is used for the second lower electrode when it is an anode. As such, forming the first lower electrode **210a** and the second lower electrode **210b** of different respective materials may be carried out by repeatedly performing patterning using photoresist and deposition, or by deposition using a shadow mask.

[0032] A first organic emission layer **230a** and a second organic emission layer **230b** are formed on the first and

second lower electrodes **210a** and **210b**, respectively. A first upper electrode **250a** and a second upper electrode **250b** are formed on the first and second organic emission layers **230a** and **230b**, respectively. The upper electrodes **250a** and **250b** are transparent electrodes, and a thin metal layer having a low work function, for example, Mg, Ca, Al, Ag, Ba, or an alloy thereof, is used to form the upper electrodes having a thickness of 100 Å or less when they are cathodes. Forming the upper electrodes **250a** and **250b** may further include forming an ITO layer on the thin metal layer.

[0033] As a result, at least one first OLED **270a** and at least one second OLED **270b** are formed in the first display portion (a) and the second display portion (b), respectively. The first OLED **270a** is a transparent OLED in which the first lower electrode **210a** and the first upper electrode **250a** are transparent electrodes to emit light in a direction toward the substrate and in a direction away from the substrate, and the second OLED **270b** is a top-emission type in which the second lower electrode **210b** is a reflective electrode and the second upper electrode **250b** is a transparent electrode to emit light only in a direction away from the substrate. Accordingly, the substrate **100** may be used to display both screens, namely, in a direction toward the substrate and in a direction away from the substrate, and the second OLED **270b** is not driven when the screen is displayed in a direction toward the substrate, thereby reducing its power consumption.

[0034] Furthermore, the OLEDs **270a** and **270b** may be passive matrix types or active matrix types. When the OLEDs **270a** and **270b** are the active matrix types, the substrate **100** has thin film transistors to be electrically connected to the lower electrodes **210a** and **210b**, respectively.

[0035] FIG. 4 is a cross-sectional view illustrating a method for fabricating a flat panel display in accordance with the third embodiment of the present invention. The flat panel display in accordance with the third embodiment is fabricated to include both a top-emission OLED and a bottom-emission OLED on one substrate.

[0036] Referring to FIG. 4, a transparent substrate **300** having a first display portion (a) and a second display portion (b) is provided. The transparent substrate **300** may be a glass substrate or a plastic substrate. At least one first lower electrode **310a** and at least one second lower electrode **310b** are formed on the first display portion (a) and the second display portion (b), respectively. The first lower electrode **310a** is a reflective electrode, and, for example, Ag, Al, Ni, Pt, or Pd is used for the first lower electrode when it is an anode. The second lower electrode **310b** is a transparent electrode, and, for example, ITO or IZO is used for the second lower electrode when it is an anode. As such, forming the first lower electrode **310a** and the second lower electrode **310b** of different respective materials may be carried out by repeatedly performing patterning using photoresist and deposition, or by deposition using a shadow mask.

[0037] A first organic emission layer **330a** and a second organic emission layer **330b** are formed on the first and second lower electrodes **310a** and **310b**, respectively. A first upper electrode **350a** and a second upper electrode **350b** are formed on the first and second organic emission layers **330a** and **330b**, respectively. The first upper electrode **350a** is a

transparent electrode, and a thin metal layer having a low work function, for example, Mg, Ca, Al, Ag, Ba, or an alloy thereof, is used to form the first upper electrode **350a** having a thickness of 100 Å or less when it is a cathode. Forming the first upper electrode **350a** may further include forming an ITO layer on the thin metal layer. The second upper electrode **350b** is a reflective electrode, and a metal layer having a low work function, for example, Mg, Ca, Al, Ag, Ba, or an alloy thereof, is used to form the second upper electrode having a thickness of 500 Å or more when it is a cathode. The first upper electrode **350a** as the transparent electrode and the second upper electrode **350b** as the reflective electrode may be formed using a shadow mask or the like, respectively.

[0038] As a result, at least one first OLED **370a** and at least one second OLED **370b** are formed in the first display portion (a) and the second display portion (b), respectively. The first OLED **370a** is a top-emission type in which the first lower electrode **310a** is a reflective electrode and the first upper electrode **350a** is a transparent electrode to emit light in a direction away from the substrate, and the second OLED **370b** is a bottom-emission type in which the second lower electrode **310b** is a transparent electrode and the second upper electrode **350b** is a reflective electrode to emit light in a direction toward the substrate. Accordingly, the substrate **300** may be used to display both screens, namely, in a direction toward the substrate and in a direction away from the substrate, and the first OLED **370a** or the second OLED **370b** is not driven when one of the screens is displayed, thereby reducing its power consumption.

[0039] Furthermore, the OLEDs **370a** and **370b** may be passive matrix types or active matrix types. When the OLEDs **370a** and **370b** are active matrix types, the substrate **300** has thin film transistors to be electrically connected to the lower electrodes **310a** and **310b**, respectively.

[0040] FIG. 5 is a cross-sectional view illustrating a method for fabricating a flat panel display in accordance with the fourth embodiment of the present invention. The flat panel display in accordance with the fourth embodiment is fabricated to include at least one bottom-emission OLED on top and bottom surfaces, respectively, of one substrate.

[0041] Referring to FIG. 5, a transparent substrate **400** having a first display portion (a) and a second display portion (b) is provided. The transparent substrate **400** may be a glass substrate or a plastic substrate, and has a top surface **401** and a bottom surface **402**. At least one first lower electrode **410a** is formed on the bottom surface **402** of the substrate **100** in the first display portion (a). The first lower electrode **410a** is made of a transparent electrode, and, for example, ITO or IZO is used for the first lower electrode when it is an anode. A first organic emission layer **430a** is formed on the first lower electrode **410a**, and a first upper electrode **450a** is formed on the first organic emission layer **430a**. The first upper electrode **450a** is a reflective electrode, and a metal layer having a low work function, for example, Mg, Ca, Al, Ag, Ba, or an alloy thereof, is used to form the first upper electrode having a thickness of 500 Å or more when it is a cathode. As a result, at least one first OLED **470a** is formed in the first display portion (a).

[0042] Next, at least one second lower electrode **410b** is formed on the top surface **401** of the substrate **100** in the second display portion (b). The second lower electrode **410b**

is a transparent electrode, and, for example, ITO or IZO is used for the second lower electrode when it is an anode. A first organic emission layer **430b** is formed on the second lower electrode **410b**, and a first upper electrode **450b** is formed on the first organic emission layer **430b**. The first upper electrode **450b** is a reflective electrode, and a metal layer having a low work function, for example, Mg, Ca, Al, Ag, Ba, or an alloy thereof, is used to form the first upper electrode having a thickness of 500 Å or more when it is a cathode. As a result, at least one second OLED **470b** is formed in the second display portion (b).

[0043] Alternatively, the lower electrodes **410a** and **410b** are formed in the first display portion (a) and the second display portion (b), respectively, the organic emission layers **430a** and **430b** are formed on the lower electrodes **410a** and **410b**, respectively, and then the upper electrodes **450a** and **450b** are formed on the organic emission layers **430a** and **430b**, respectively, so that the first OLED **470a** and the second OLED **470b** are formed.

[0044] The OLEDs **470a** and **470b** may be bottom-emission types in which the lower electrodes **410a** and **410b** are transparent electrodes and the upper electrodes **450a** and **470b** are reflective electrodes to emit light in a direction toward the substrate. However, the first OLED **470a** may be formed on the bottom surface **402** of the substrate while the second OLED **470b** may be formed on the top surface **401** of the substrate to thereby fabricate a flat panel display for emitting light in directions opposite to each other. Accordingly, the substrate **400** may be used to display both screens, namely, in a direction toward the substrate and in a direction away from the substrate, and the first OLED **470a** or the second OLED **470b** is not driven when one screen is displayed in any one of the directions, thereby reducing power consumption.

[0045] Furthermore, the OLEDs **470a** and **470b** may be passive matrix types or active matrix types. When the OLEDs **470a** and **470b** are active matrix types, the substrate **100** has thin film transistors to be electrically connected to the lower electrodes **410a** and **410b**, respectively.

[0046] FIG. 6 is a cross-sectional view illustrating a method for fabricating a flat panel display in accordance with the fifth embodiment of the present invention. The flat panel display in accordance with the fifth embodiment is fabricated to include at least one top-emission OLED on top and bottom surfaces, respectively, of one substrate.

[0047] Referring to FIG. 6, a transparent substrate **500** having a first display portion (a) and a second display portion (b) is provided. The transparent substrate **500** may be a glass substrate or a plastic substrate, and has a top surface **501** and a bottom surface **502**. At least one first lower electrode **510a** is formed on the top surface **501** of the substrate **500** in the first display portion (a). The first lower electrode **510a** is a reflective electrode, and, for example, Ag, Al, Ni, Pt, or Pd is used for the first lower electrode when it is an anode. A first organic emission layer **530a** is formed on the first lower electrode **510a**, and a first upper electrode **550a** is formed on the first organic emission layer **530a**. The first upper electrode **550a** is a transparent electrode, and a thin metal layer having a low work function, for example, Mg, Ca, Al, Ag, Ba, or an alloy thereof, is used to form the first upper electrode having a thickness of 100 Å or less when it is a cathode. Forming the first upper electrode

550a may further include forming an ITO layer on the thin metal layer. As a result, at least one first OLED **570a** is formed in the first display portion (a).

[0048] Next, at least one first lower electrode **510b** is formed on the bottom surface **502** of the substrate **500** in the second display portion (b). The first lower electrode **510b** is a reflective electrode, and, for example, Ag, Al, Ni, Pt, or Pd is used for the first lower electrode when it is an anode. A first organic emission layer **530b** is formed on the first lower electrode **510b**, and a first upper electrode **550b** is formed on the first organic emission layer **530b**. The first upper electrode **550b** is made of a transparent electrode, and a thin metal layer having a low work function, for example, Mg, Ca, Al, Ag, Ba, or an alloy thereof, is used to form the first upper electrode having a thickness of 100 Å or less when it is a cathode. Forming the first upper electrode **550b** may further include forming an ITO layer on the thin metal layer. As a result, at least one second OLED **570b** is formed in the second display portion (b).

[0049] Alternatively, the lower electrodes **510a** and **510b** are formed in the first display portion (a) and the second display portion (b), respectively, and the organic emission layers **530a** and **530b** are formed on the lower electrodes **510a** and **510b**, respectively, and then the upper electrodes **550a** and **550b** are formed on the organic emission layers **530a** and **530b**, respectively, so that the first OLED **570a** and the second OLED **570b** are formed.

[0050] The OLEDs **570a** and **570b** may be bottom-emission types in which the lower electrodes **510a** and **510b** are reflective electrodes and the upper electrodes **550a** and **550b** are transparent electrodes to emit light in a direction away from the substrate. However, the first OLED **570a** may be formed on the top surface **501** of the substrate while the second OLED **570b** may be formed on the bottom surface **502** of the substrate to thereby fabricate a flat panel display for emitting light in directions opposite to each other. Accordingly, the substrate **500** may be used to display both screens, namely, in a direction toward the substrate and in a direction away from the substrate, and the first OLED **570a** or the second OLED **570b** is not driven when one screen is displayed in any one of the directions, thereby reducing power consumption.

[0051] Furthermore, the OLEDs **570a** and **570b** may be passive matrix types or active matrix types. When the OLEDs **570a** and **570b** are active matrix types, the substrate **500** has thin film transistors to be electrically connected to the lower electrodes **510a** and **510b**, respectively.

[0052] FIG. 7 is a cross-sectional view illustrating a method for fabricating a flat panel display in accordance with the sixth embodiment of the present invention. The flat panel display in accordance with the sixth embodiment is fabricated to include a transparent OLED and a bottom-emission OLED on one substrate.

[0053] Referring to FIG. 7, a transparent substrate **600** having a first display portion (a) and a second display portion (b) is provided. The transparent substrate **600** may be a glass substrate or a plastic substrate. A buffer layer **601** may be formed on the transparent substrate **600**. The buffer layer **601** may be formed of a silicon oxide layer, a silicon nitride layer, a silicon oxynitride layer, or a stacked layer thereof.

[0054] A first semiconductor layer **602a** and a second semiconductor layer **602b** are formed on the buffer layer **601** of the first display portion (a) and the second display portion (b), respectively. Formation of the semiconductor layers **602a** and **602b** may be carried out by depositing an amorphous silicon layer on the buffer layer **601**, crystallizing the amorphous silicon layer to form a polycrystalline silicon layer, and patterning the polycrystalline silicon layer. The crystallization may be carried out by employing a solid phase crystallization (SPC) method, an excimer laser annealing (ELA) method, a sequential lateral solidification (SLS) method, a metal induced crystallization (MIC), or a metal induced lateral crystallization (MILC) method.

[0055] A gate insulating layer **603** is formed on the semiconductor layers **602a** and **602b**. The gate insulating layer **603** may be formed of a silicon oxide layer, a silicon nitride layer, a silicon oxynitride layer, or a stacked layer thereof. A gate conductive layer is deposited on the gate insulating layer **603**, and the gate conductive layer is patterned to thereby form a first gate electrode **604a** and a second gate electrode **604b** which overlap with the first and second semiconductor layers **602a** and **602b**, respectively.

[0056] Impurities are implanted into the semiconductor layers **602a** and **602b** using the gate electrodes **604a** and **604b** as a mask to form first source region **602a_1** and first drain region **602a_2** in the first semiconductor layer **602a**, and second source region **602b_1** and second drain region **602b_2** in the second semiconductor layer **602b**. As a result, a first channel region **602a_2** is defined between the first source and drain regions **602a_1** and **602a_2**, respectively, and a second channel region **602b_2** is defined between the second source and drain regions **602b_1** and **602b_2**, respectively.

[0057] Next, an interlayer **605** is formed on the gate electrodes **604a** and **604b**. First contact holes for exposing the first source and drain regions **602a_1** and **602a_2**, respectively, and second contact holes for exposing the second source and drain regions **602b_1** and **602b_2**, respectively, are formed within the interlayer **605**. A source/drain conductive layer is deposited on the substrate on which contact holes are already formed, and is patterned to thereby form first source electrode **606a_1**, first drain electrode **606a_3**, second source electrode **606b_1**, and second drain electrode **606b_3**. The first source and drain electrodes **606a_1** and **606a_3**, respectively, are connected to the first source and drain regions **602a_1** and **602a_3**, respectively, through the first contact holes. The second source and drain electrodes **606b_1** and **606b_3**, respectively, are connected to the second source and drain regions **602b_1** and **602b_3**, respectively, through the second contact holes. The first semiconductor layer **602a**, the first gate electrode **604a**, and the first source and drain electrodes **606a_1** and **606a_3**, respectively, form a first thin film transistor, and the second semiconductor layer **602b**, the second gate electrode **604b**, and the second source and drain electrodes **606b_1** and **606b_3**, respectively, form a second thin film transistor.

[0058] A passivation layer **607** is then formed on the source electrodes **606a_1** and **606b_1** and drain electrodes **606a_3** and **606b_3**. A first via hole for exposing the first drain electrode **606a_3**, and a second via hole for exposing the second drain electrode **606b_3**, are formed within the passivation layer **607**.

[0059] A first lower electrode **610a** connected to the first drain electrodes **606a_3** through the first via hole, and a second lower electrode **610b** connected to the second drain electrodes **606b_3** through the second via hole, are formed on the passivation layer **607**. The lower electrodes **610a** and **610b** are transparent electrodes, and, for example, ITO or IZO is used for the lower electrodes when they are anodes.

[0060] A pixel defining layer **615** is formed on the first and second lower electrodes **610a** and **610b**, respectively, so as to have openings for exposing the first and second lower electrodes **610a** and **610b**, respectively. First and second organic emission layers **630a** and **630b**, respectively, are formed on the first and second lower electrodes **610a** and **610b**, respectively, exposed within the openings. First and second upper electrodes **650a** and **650b**, respectively, are formed on the first and second organic emission layers **630a** and **630b**, respectively. The first upper electrode **650a** is a transparent electrode, and a thin metal layer having a low work function, for example, Mg, Ca, Al, Ag, Ba, or an alloy thereof, is used to form the first upper electrode having a thickness of 100 Å or less when it is a cathode. Formation of the first upper electrode **650a** may further include forming an ITO layer on the thin metal layer. The second upper electrode **650b** is a reflective electrode, and a metal layer having a low work function, for example, Mg, Ca, Al, Ag, Ba, or an alloy thereof, is used to form the second upper electrode having a thickness of 500 Å or more when it is a cathode. The first upper electrode **650a** as the transparent electrode and the second upper electrode **650b** as the reflective electrode may each be formed using a shadow mask or the like.

[0061] Accordingly, at least one first OLED **670a** and at least one second OLED **670b** are formed in the first display portion (a) and the second display portion (b), respectively. The first OLED **670a** is a transparent OLED in which the first lower electrode **610a** and the first upper electrode **650a** are transparent electrodes to emit light in a direction toward the substrate and in a direction away from the substrate, and the second OLED **670b** is a bottom-emission type in which the second lower electrode **610b** is a transparent electrode and the second upper electrode **650b** is a reflective electrode to emit light only in a direction toward the substrate.

[0062] Furthermore, the first OLED **670a** and the second OLED **670b**, in particular, the first lower electrode **610a** and the second lower electrode **610b**, are electrically connected to the first and second thin film transistors, respectively. In addition, gate driving circuits and data driving circuits shown in FIG. 1 may be formed while forming the thin film transistors.

[0063] FIG. 8 is a cross-sectional view illustrating a method for fabricating a flat panel display in accordance with the seventh embodiment of the present invention. The flat panel display in accordance with the seventh embodiment is fabricated to include a transparent OLED and a top-emission OLED on one substrate, and is the same as that of the above-mentioned sixth embodiment except for the following description.

[0064] Referring to FIG. 8, a transparent substrate **700** having a first display portion (a) and a second display portion (b) is provided. A buffer layer **701** is formed on the transparent substrate **700**, and a first semiconductor layer **702a** and a second semiconductor layer **702b** are formed on

the buffer layer **701**. A gate insulating layer **703** is formed on the semiconductor layers **702a** and **702b**, and a first gate electrode **704a** and a second gate electrode **704b** are formed on the gate insulating layer **703**. Impurities are implanted into the semiconductor layers **702a** and **702b** using the gate electrodes **704a** and **704b** as a mask, so that first source region **702a_1** and first drain region **702a_3** are formed in the first semiconductor layer **702a**, and second source region **702b_1** and first drain region **702b_3** are formed in the second semiconductor layer **702b** while a first channel region **702a_2** and a second channel region **702b_2** are simultaneously defined.

[0065] Next, an interlayer **705** is formed on the gate electrodes **704a** and **704b**. First source and drain electrodes **706a_1** and **706a_3**, respectively, connected to the first source and drain regions **702a_1** and **702a_3**, respectively, and second source and drain electrodes **706b_1** and **706b_3**, respectively, connected to the second source and drain regions **702b_1** and **702b_3**, respectively, are formed on the interlayer **705**. The first semiconductor layer **702a**, the first gate electrode **704a**, and the first source and drain electrodes **706a_1** and **706a_3**, respectively, form a first thin film transistor, and the second semiconductor layer **702b**, the second gate electrode **704b**, and the second source and drain electrodes **706b_1** and **706b_3**, respectively, form a second thin film transistor.

[0066] A passivation layer **707** is formed on the source electrodes **706a_1** and **706b_1** and drain electrodes **706a_3** and **706b_3**. A first via hole for exposing the first drain electrode **706a_3** and a second via hole for exposing the second drain electrode **706b_3** are formed within the passivation layer **707**.

[0067] A first lower electrode **710a** connected to the first drain electrode **706a_3** through the first via hole, and second lower electrode **710b** connected to the second drain electrode **706b_3** through the second via hole, are formed on the passivation layer **707**. The first lower electrode **710a** is a transparent electrode, and, for example, ITO or IZO is used for the first lower electrode when it is an anode. The second lower electrode **710b** is a reflective electrode, and, for example, Ag, Al, Ni, Pt, Pd, or an alloy thereof is used for the second lower electrode when it is an anode. Formation of the first lower electrode **710a** and the second lower electrode **710b** of different respective materials may be carried out by repeatedly performing patterning using photoresist and deposition, or by deposition using a shadow mask.

[0068] A pixel defining layer **715** is formed on the first and second lower electrodes **710a** and **710b**, respectively so as to have openings for exposing the first and second lower electrodes **710a** and **710b**, respectively. A first organic emission layer **730a** and a second organic emission layer **730b** are formed on the first and second lower electrodes **710a** and **710b**, respectively, exposed within the openings. First and second upper electrodes **750a** and **750b**, respectively, are formed on the first and second organic emission layers **730a** and **730b**, respectively. The upper electrodes **750a** and **750b** are made of transparent electrodes, and a thin metal layer having a low work function, for example, Mg, Ca, Al, Ag, Ba, or an alloy thereof, is used to form the upper electrodes having a thickness of 100 Å or less when they are

cathodes. Formation of the upper electrodes **750a** and **750b** may further include forming an ITO layer on the thin metal layer.

[0069] Accordingly, at least one first OLED **770a** and at least one second OLED **770b** are formed in the first display portion (a) and the second display portion (b), respectively. The first OLED **770a** is a transparent OLED in which the first lower electrode **710a** and the first upper electrode **750a** are transparent electrodes to emit light in a direction toward the substrate and in a direction away from the substrate, and the second OLED **770b** is a top-emission type in which the second lower electrode **710b** is a reflective electrode and the second upper electrode **750b** is a transparent electrode to emit light in a direction away from the substrate.

[0070] Furthermore, the first OLED **770a** and the second OLED **770b**, in particular, the first lower electrode **710a** and the second lower electrode **710b**, are electrically connected to the first and second thin film transistors, respectively. In addition, gate driving circuits and data driving circuits shown in FIG. 1 may be formed while forming the thin film transistors.

[0071] FIG. 9 is a cross-sectional view illustrating a method for fabricating a flat panel display in accordance with the eighth embodiment of the present invention. The flat panel display in accordance with the eighth embodiment is fabricated to include a top-emission OLED and a bottom-emission OLED on one substrate, and is substantially the same as that of the above-mentioned sixth embodiment except for the following description.

[0072] Referring to FIG. 9, a transparent substrate **800** having a first display portion (a) and a second display portion (b) is provided. A buffer layer **801** is formed on the transparent substrate **800**, and a first semiconductor layer **802a** and a second semiconductor layer **802b** are formed on the buffer layer **801**. A gate insulating layer **803** is formed on the semiconductor layers **802a** and **802b**, and a first gate electrode **804a** and a second gate electrode **804b** are formed on the gate insulating layer **803**. Impurities are implanted into the semiconductor layers **802a** and **802b** using the gate electrodes **804a** and **804b** as a mask, so that first source region **802a_1** and first drain region **802a_3** are formed in the first semiconductor layer **802a**, and second source region **802b_1** and second drain region **802b_3** are formed in the second semiconductor layer **802b** while a first channel region **802a_2** and a second channel region **802b_2** are simultaneously defined.

[0073] Next, an interlayer **805** is formed on the gate electrodes **804a** and **804b**. First source electrode **806a_1** and first drain electrode **806a_3** connected to the first source and drain regions **802a_1** and **802a_3**, respectively, and second source electrode **806b_1** and second drain electrode **806b_3** connected to the second source and drain regions **802b_1** and **802b_3**, respectively, are formed on the interlayer **805**. The first semiconductor layer **802a**, the first gate electrode **804a**, and the first source and drain electrodes **806a_1** and **806a_3**, respectively, form a first thin film transistor, and the second semiconductor layer **802b**, the second gate electrode **804b**, and the second source and drain electrodes **806b_1** and **806b_3**, respectively, form a second thin film transistor.

[0074] A passivation layer **807** is formed on the source electrodes **806a_1** and **806b_1** and drain electrodes **806a_3**

and **806b_3**. A first via hole for exposing the first drain electrode **806a_3** and a second via hole for exposing the second drain electrode **806b_3** are formed within the passivation layer **807**.

[0075] A first lower electrode **810a** connected to the first drain electrode **806a_3** through the first via hole, and second lower electrode **810b** connected to the second drain electrode **806b_3** through the second via hole, are formed on the passivation layer **807**. The first lower electrode **810a** is a reflective electrode, and, for example, Ag, Al, Ni, Pt, or Pd is used for first the lower electrode when it is an anode. The second lower electrode **810b** is a transparent electrode, and, for example, ITO or IZO is used for the second lower electrode when it is an anode. As such, formation of the first lower electrode **810a** and the second lower electrode **810b** of respective different respective materials may be carried out by repeatedly performing patterning using photoresist and deposition, or by deposition using a shadow mask.

[0076] A first organic emission layer **830a** and a second organic emission layer **830b** are formed on the first and second lower electrodes **810a** and **810b**, respectively. First and second upper electrodes **850a** and **850b**, respectively, are formed on the first and second organic emission layers **830a** and **830b**, respectively. The first upper electrode **850a** is a transparent electrode, and a thin metal layer having a low work function, for example, Mg, Ca, Al, Ag, Ba, or an alloy thereof, is used to form the first upper electrode having a thickness of 100 Å or less when it is a cathode. Formation of the first upper electrode **850a** may further include forming an ITO layer on the thin metal layer. The second upper electrode **850b** is a reflective electrode, and a metal layer having a low work function, for example, Mg, Ca, Al, Ag, Ba, or an alloy thereof, is used to form the second upper electrode having a thickness of 500 Å or more when it is a cathode. The first upper electrode **850a** as the transparent electrode and the second upper electrode **850b** as the reflective electrode are formed using a shadow mask or the like, respectively.

[0077] Accordingly, at least one first OLED **870a** and at least one second OLED **870b** are formed in the first display portion (a) and the second display portion (b), respectively. The first OLED **870a** is a top-emission type in which the first lower electrode **810a** is a reflective electrode and the first upper electrode **850a** is a transparent electrode to emit light in a direction away from the substrate, and the second OLED **870b** is a bottom-emission type in which the second lower electrode **810b** is a transparent electrode and the second upper electrode **850b** is a reflective electrode to emit light in a direction toward the substrate.

[0078] Furthermore, the first OLED **870a** and the second OLED **870b**, in particular, the first lower electrode **810a** and the second lower electrode **810b**, are electrically connected to the first and second thin film transistors, respectively. In addition, gate driving circuits and data driving circuits shown in FIG. 1 may be formed while forming the thin film transistors.

[0079] FIG. 10 is a plan view illustrating a folder type mobile phone in the folded and unfolded states employing the flat panel display in accordance with any one of the first, second, sixth and seventh embodiments of the present invention.

[0080] Referring to FIG. 10, the mobile phone comprises a cover **10** and a main body **20**, input buttons **25** are arranged

on the main body **20**, and the cover **10** and the main body **20** are connected to each other by an interconnection portion **30**. The cover **10** has an external screen **11** on its external surface, and has a first internal screen **12** and a second internal screen **13** on its internal surface. In this case, the external screen **11** is positioned to correspond to the first internal screen **12**. The first OLED (**170a** of **FIG. 2**, **270a** of **FIG. 3**, **670a** of **FIG. 7**, and **770a** of **FIG. 8**), which is a transparent OLED positioned in the first display portion (a) of the flat panel display in accordance with the first, second, sixth or seventh embodiment, displays screens through the external screen **11** and the first internal screen **12**. The second OLED (**170b** of **FIG. 2**, **270b** of **FIG. 3**, **670b** of **FIG. 7**, and **770b** of **FIG. 8**), which is a top-emission type or a bottom-emission type positioned in the second display portion (b) of the flat panel display in accordance with the first, second, sixth or seventh embodiment, displays the screen through the second internal screen **13**.

[0081] As such, the flat panel display in accordance with the first, second, sixth or seventh embodiment may display screens on both sides using one substrate so that the thickness of the folder type mobile phone employing the flat panel display may be reduced. The second OLED (**170b** of **FIG. 2**, **270b** of **FIG. 3**, **670b** of **FIG. 7**, and **770b** of **FIG. 8**), namely, the second internal screen **13**, is not allowed to display when the first OLED (**170a** of **FIG. 2**, **270a** of **FIG. 3**, **670a** of **FIG. 7**, and **770a** of **FIG. 8**), namely, the external screen **11**, is displayed so that power consumption of the mobile phone may be reduced. In addition to being applied to the above-mentioned mobile phone, the flat panel display of the present invention may also be applied to electronic equipment for displaying screens on both sides through internal and external screens so as to obtain the same effect.

[0082] **FIG. 11** is a plan view illustrating a folder type mobile phone in the folded and unfolded states employing the flat panel display in accordance with any one of the third, fourth, fifth and eighth embodiments of the present invention.

[0083] Referring to **FIG. 11**, the mobile phone comprises a cover **10** and a main body **20**, input buttons **25** are arranged on the main body **20**, and the cover **10** and the main body **20** are connected to each other by an interconnection portion **30**. The cover **10** has an external screen **15** on its external surface, and has an internal screen **16** on its internal surface. The first OLED (**370a** of **FIG. 4**, **470a** of **FIG. 5**, **570a** of **FIG. 6**, and **870a** of **FIG. 9**), which is positioned in the first display portion (a) of the flat panel display in accordance with the third, fourth, fifth or eighth embodiment, displays the screen through the external screen **15**. The second OLED (**370b** of **FIG. 4**, **470b** of **FIG. 5**, **570b** of **FIG. 6**, and **870b** of **FIG. 9**), which is positioned in the second display portion (b) of the flat panel display in accordance with the third, fourth, fifth or eighth embodiment, displays the screen through the internal screen **16**.

[0084] As such, the flat panel display in accordance with the third, fourth, fifth or eighth embodiment may display screens on both sides using one substrate so that the thickness of the folder type mobile phone employing the flat panel display may be reduced. However, the screens are not displayed on both sides at the same time. The second OLED (**370b** of **FIG. 4**, **470b** of **FIG. 5**, **570b** of **FIG. 6**, and **870b** of **FIG. 9**), namely, the internal screen **16**, is not allowed to

be displayed when the first OLED (**370a** of **FIG. 4**, **470a** of **FIG. 5**, **570a** of **FIG. 6**, and **870a** of **FIG. 9**), namely, the external screen **15**, is displayed so that power consumption of the mobile phone may be reduced. In addition to being applied to the above-mentioned mobile phone, the flat panel display of the present invention may also be applied to electronic equipment for displaying screens on both sides through the internal and external screens to obtain the same effect.

[0085] As mentioned above, in accordance with the present invention, a flat panel display is fabricated so that one substrate is used to display the screens on both sides, and one of the sides is displayed while the other is not allowed to be displayed. Accordingly, the thickness of the electronic equipment employing the flat panel display may be reduced, and power consumption of the electronic equipment may also be reduced.

[0086] Although the present invention has been described with reference to certain exemplary embodiments thereof, it will be understood by those skilled in the art that a variety of modifications and variations may be made to the present invention without departing from the spirit or scope of the present invention as defined in the appended claims, and their equivalents.

What is claimed is:

1. A flat panel display, comprising:

a transparent substrate having a first display portion and a second display portion;

at least one first organic light emitting diode positioned in the first display portion for emitting light in at least a first direction perpendicular to the transparent substrate, and having a first lower electrode, a first upper electrode, and a first organic emission layer interposed between the first lower electrode and the first upper electrode; and

at least one second organic light emitting diode positioned in the second display portion for emitting light in a second direction opposite to the first direction, and having a second lower electrode, a second upper electrode, and a second organic emission layer interposed between the second lower electrode and the second upper electrode.

2. The flat panel display as recited in claim 1, wherein said at least one first organic light emitting diode and said at least one second organic light emitting diode are positioned on a same surface of the transparent substrate.

3. The flat panel display as recited in claim 2, wherein the first lower electrode comprises a reflective electrode, the first upper electrode comprises a transparent electrode, the second lower electrode comprises a transparent electrode, and the second upper electrode comprises a reflective electrode.

4. The flat panel display as recited in claim 2, wherein both the first lower electrode and the first upper electrode comprise transparent electrodes, the second lower electrode comprises a transparent electrode, and the second upper electrode comprises a reflective electrode.

5. The flat panel display as recited in claim 2, wherein both the first lower electrode and the first upper electrode comprise transparent electrodes, the second lower electrode comprises a reflective electrode, and the second upper electrode comprises a transparent electrode.

6. The flat panel display as recited in claim 1, wherein said at least one first organic light emitting diode is positioned on a surface opposite to a surface on which said at least one second organic light emitting diode is positioned.

7. The flat panel display as recited in claim 6, wherein the first lower electrode comprises a transparent electrode, the first upper electrode comprises a reflective electrode, the second lower electrode comprises a transparent electrode, and the second upper electrode comprises a reflective electrode.

8. The flat panel display as recited in claim 6, wherein the first lower electrode comprises a reflective electrode, the first upper electrode comprises a transparent electrode, the second lower electrode comprises a reflective electrode, and the second upper electrode comprises a transparent electrode.

9. The flat panel display as recited in claim 1, further comprising:

a first thin film transistor electrically connected to said at least one first organic light emitting diode; and

a second thin film transistor electrically connected to said at least one second organic light emitting diode.

10. The flat panel display as recited in claim 9, wherein said at least one first organic light emitting diode and said at

least one second organic light emitting diode are positioned on a same surface of the transparent substrate.

11. The flat panel display as recited in claim 10, wherein the first lower electrode comprises a reflective electrode, the first upper electrode comprises a transparent electrode, the second lower electrode comprises a transparent electrode, and the second upper electrode comprises a reflective electrode.

12. The flat panel display as recited in claim 10, wherein both the first lower electrode and the first upper electrode comprise transparent electrodes, the second lower electrode comprises a transparent electrode, and the second upper electrode comprises a reflective electrode.

13. The flat panel display as recited in claim 10, wherein both the first lower electrode and the first upper electrode comprise transparent electrodes, the second lower electrode comprises a reflective electrode, and the second upper electrode comprises a transparent electrode.

14. The flat panel display as recited in claim 1, wherein the flat panel display is used for a folder type mobile phone.

* * * * *

专利名称(译)	平板显示器，用于在两侧显示屏幕		
公开(公告)号	US20050110403A1	公开(公告)日	2005-05-26
申请号	US10/980338	申请日	2004-11-04
[标]申请(专利权)人(译)	韩东WON 金炳HEE		
申请(专利权)人(译)	韩东-WON 金炳HEE		
当前申请(专利权)人(译)	三星DISPLAY CO. , LTD.		
[标]发明人	HAN DONG WON KIM BYUNG HEE		
发明人	HAN, DONG-WON KIM, BYUNG-HEE		
IPC分类号	H05B33/00 H01J1/62 H01J63/04 H01L27/32		
CPC分类号	H01L27/3267 H01L2251/5323 H01L2251/5315 H01L27/3286		
优先权	1020030079945 2003-11-12 KR		
其他公开文献	US7170225		
外部链接	Espacenet USPTO		

摘要(译)

一种平板显示器，包括：透明基板，具有第一显示部分和第二显示部分；至少一个第一有机发光二极管，位于第一显示部分，用于在垂直于透明基板的第一方向上发光，并具有第一下电极，第一上电极和介于第一下电极之间的第一有机发光层电极和第一上电极；至少一个第二有机发光二极管，位于第二显示部分，用于沿与第一方向相反的第二方向发光，并具有第二下电极，第二上电极和介于第二下电极之间的第二有机发光层下电极和第二上电极。结果，使用一个基板制造平板显示器以显示两个屏幕，使得显示其中一个屏幕而不显示另一个屏幕。因此，可以减小采用平板显示器的电子设备的厚度，并且还可以降低电子设备的功耗。

